

SIM2 XTV

THE INVISIBLE LARGE DISPLAY

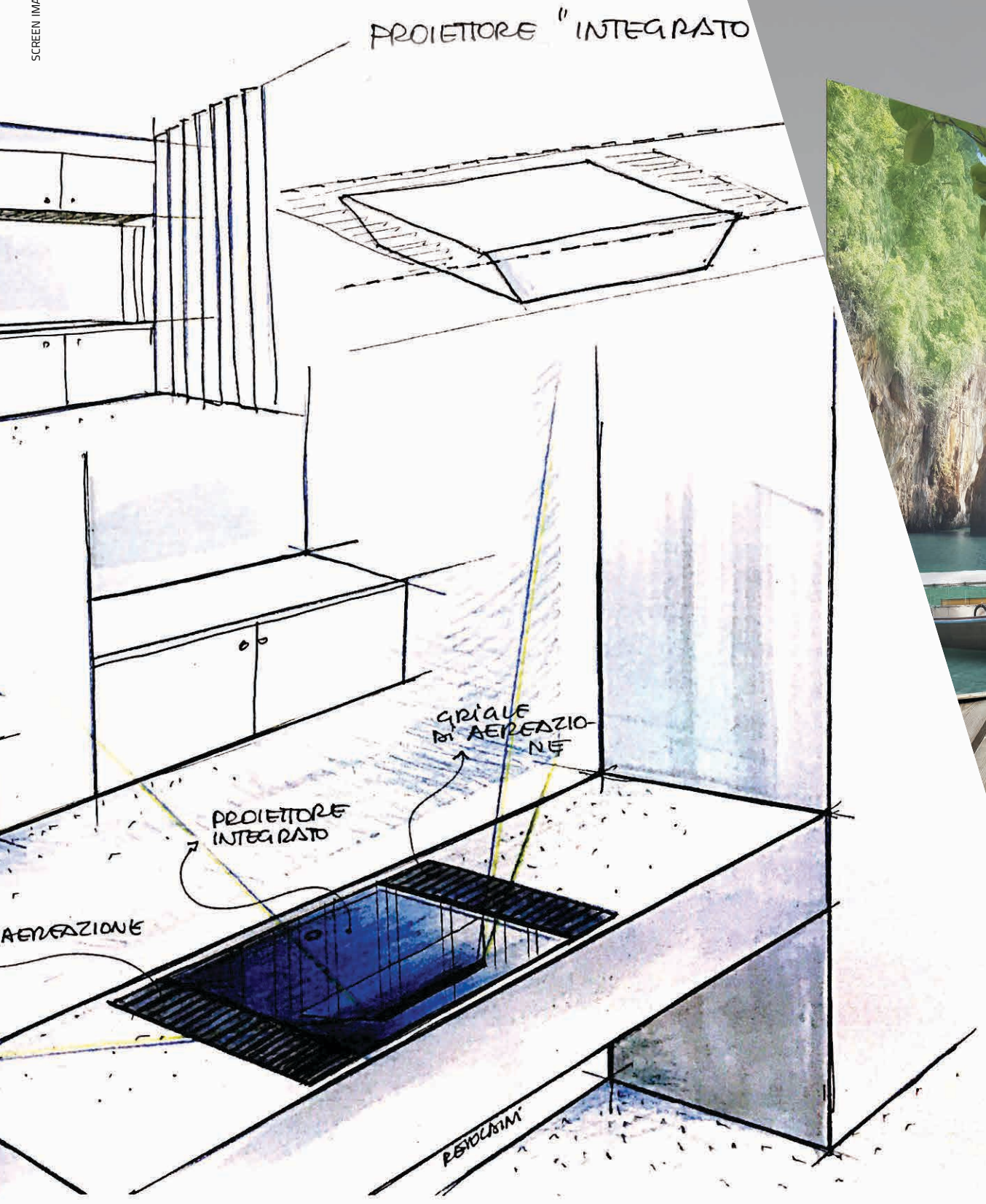



EXTRAORDINARILY ONE-OF-A-KIND

- Discreet high-tech display
- Designed to be positioned close to the wall
- SIM2 quality images up to 110 inches in size
- Stylish made-in-Italy design
- Crystal-glass finish for a luxurious feel
- 16 special coating layers applied to crystal glass
- Powered by LASER and DLP® technology
- Brightness up to 2900 lumens



SIM2xTV

A NEW WAY OF THINKING

Create premium image entertainment in any environment with SIM2xTV⁽¹⁾. This new patented SIM2 model combines the excitement of the big screen with the most discreet display device ever created for a fully immersive viewing experience.

SIM2xTV can be placed close to a wall, screen or vertical flat surface and display your favorite content in stunning detailed clarity up to a size of 110 inches.

⁽¹⁾ Patents pending

WHAT IS SIM2 xTV? ENVISION A NEW VIEWING EXPERIENCE

Designed without compromise, SIM2xTV⁽¹⁾ is the most unique of products, a beautifully engineered embodiment of a new way of thinking about creating the 'big screen' at home or in any other viewing environment. Thanks to the latest LASER illumination technology, SIM2xTV delivers up to 2900 ANSI Lumens of light output, over 20.000 hours of viewing and stunning color accuracy. Its innovative ultra-short throw lens enables SIM2xTV to produce up to 110" images from just a short distance away from the wall or screen. SIM2xTV is housed in a pure crystal-glass cabinet⁽²⁾ - designed² by Giorgio Revoldini - that makes a dramatic statement in interior design: a classic, distinctive and timeless piece of art.

⁽¹⁾ Patents pending

⁽²⁾ Patents pending on cabinet design

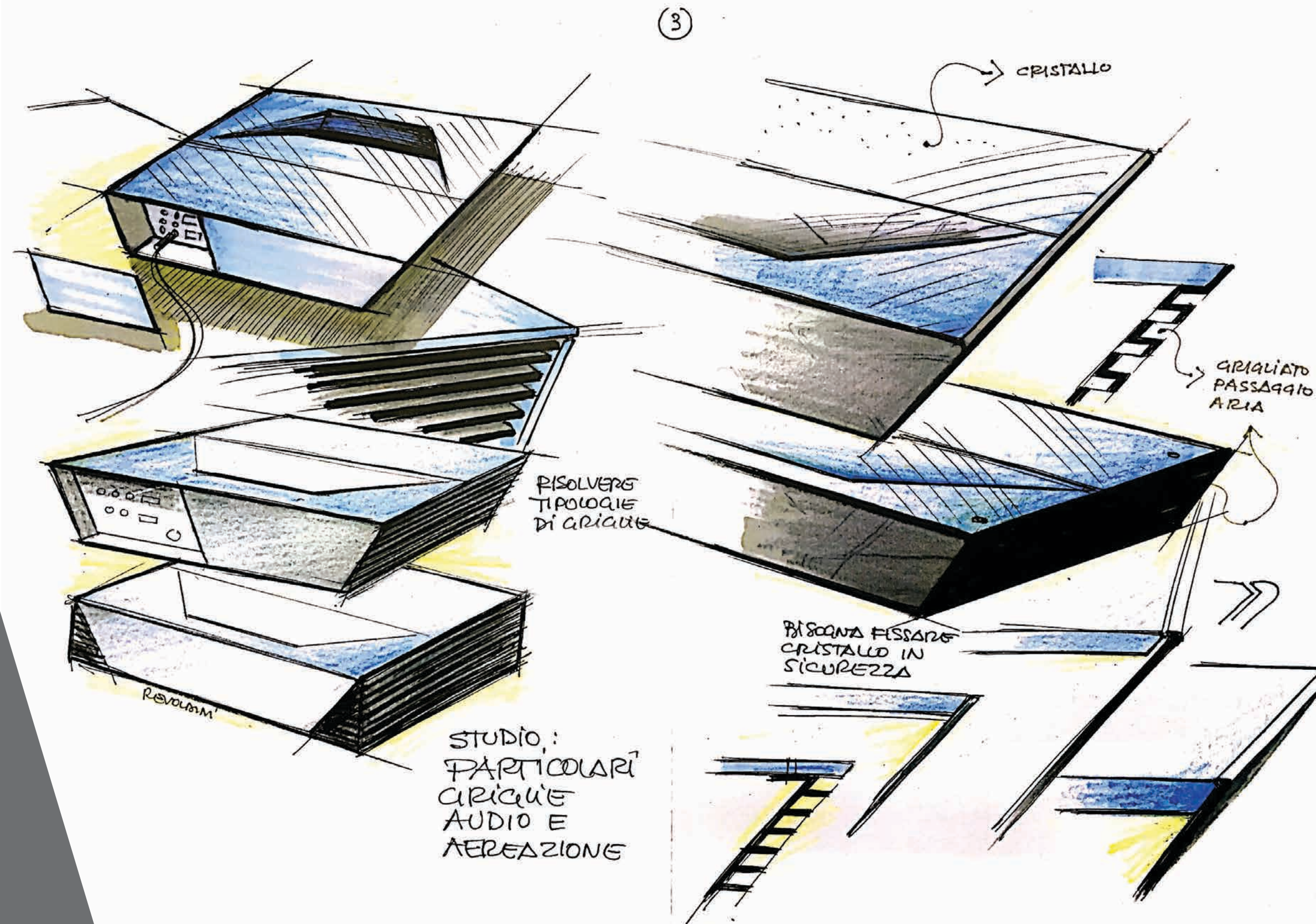

THE BIG SCREEN MADE EASY

SIM2xTV⁽¹⁾ is the result of years of intense research and passion devoted to the creation of a new concept, fully integrating visual entertainment with interior design. SIM2's world-renowned R&D department challenged itself to combine the latest technological advances, extraordinary design thinking and top-class performance into a product that is unmistakably SIM2. The use of LASER technology allows SIM2xTV to reach a maximum brightness of 2900 Ansi Lumens almost instantaneously. Also, LASER technology makes the SIM2xTV a truly "Green display": no mercury lamps and no need of lamp replacement, thus avoiding the pollution caused during lamp disposal.

As an elegant alternative solution to large, cumbersome flat TVs, SIM2xTV integrates beautifully into any living space. The crystal glass⁽¹⁾ surface and aluminum finishes add a luxurious feel to the product.

⁽¹⁾ Patents pending

FREESTANDING TO COMPLEMENT THE HOME DECOR

SIM2 xTV⁽¹⁾ is a discreet design perfect for adding a special and unique touch to suit any room style (office, theater, luxury and fashion stores, or other environments), while creating a fully immersive SIM2-quality image when you want it.

The ultra-short throw ratio lens allows you to place the SIM2xTV close to the wall to achieve an impressive image size up to 110" diagonal.

SIM2xTV is designed to be projected on to any flat, light colored surface depending on your wishes.

⁽¹⁾ Patents pending





ABOVE OR BELOW WALL OR SCREEN

THE CHOICE IS YOURS

A special lens makes SIM2xTV⁽¹⁾ highly adaptable to different viewing environments, and gives it the ultimate flexibility in installation. SIM2xTV is perfect for Hi-class board rooms, top restaurants and shops, yachts, and museums.

SIM2xTV has three HDMI inputs to easily connect video sources (UHD BD player, satellite/cable DVR, computers/servers, media streamers, games console, etc.), and it can be easily integrated into a control system via RS232 connection. Wireless connectivity can be achieved via a media streaming device such as Google's ChromeCast (via HDMI).

⁽¹⁾ Patents pending.

AVANTGARDE TECHNOLOGY

SIM2xTV features a cabinet made of a special high-tech crystal-glass⁽¹⁾ crafted specifically to optimize image performance.

An elaborate process is applied to each surface of the crystal-glass to ensure that any unwanted stray light is tightly controlled. SIM2's R&D department used complex raytracing analysis to finalize the specifications of the coatings.

SIM2xTV is an all-digital device using laser hybrid illumination and DLP® picture technology to create images that are finely-tuned to reproduce the diversity of colors, up to 2,900 ANSI lumen light output, exceptional clarity and extended dynamics expected of a SIM2 product.

⁽¹⁾ Patents pending



DESIGN MEETS TECHNOLOGY

**PRESTIGIOUS AND ETERNALLY
CONTEMPORARY**

A perfect balance of beautiful design⁽¹⁾ and exceptional materials to satisfy the most refined tastes. SIM2 xTV blends a uniquely sophisticated combination of modernity, elegance, traditional craftsmanship, and luxury. Designer Giorgio Revoldini has chosen an eternally contemporary shape enhanced with crystal-glass⁽¹⁾, a pure and sustainable material, to bring a new dimension in luxury in product design. Crystal-glass is resistant to light and high/low temperature colorations, retaining its lustrous finish even after many years of use. And, from a purely aesthetic point of view, crystal glass is simply stunning. We are all drawn to it. It is synonymous with quality.

⁽¹⁾ Patents pending.

ITALIAN DESIGN & STYLE

Italy is recognized as being a worldwide trendsetter and leader in design. SIM2 is an Italian company that for over twenty years has designed and manufactured videoprojectors and displays that are truly deserving of this world-recognized symbol of excellence. Choosing a SIM2 product means experiencing a wealth of positive emotions, whilst enjoying your favorite visual entertainment, it also means enjoying superior technology, functionality, versatility and reliability.





SIM2 xTV INV

INVISIBLE IS PART OF THE CONCEPT

SIM2 xTV⁽¹⁾ is a discreet patented high-tech display device, available in either freestanding or built-in versions⁽²⁾, designed to be positioned close to the wall, either standing on, or built-into a piece of furniture - or even ceiling-mounted.

For those who wish to seamlessly integrate the display into the home's design and minimize the visual impact on the décor, SIM2 has engineered the SIM2xTV INV⁽³⁾ model.

SIM2xTV INV is designed to be incorporated⁽³⁾ into a piece of furniture or, rather like a luxury light fixture, into a ceiling design feature, to become an integral part of your living space.

⁽¹⁾ Patents pending.

⁽²⁾ Two models available: freestanding (SIM2 xTV) or built-in (SIM2 xTV INV)

⁽³⁾ Contact your SIM2 Sales representative or SIM2 office or send an email to sim2xtv@sim2.com for additional details, exact product measurements and info on installation prior to order.

SIM2 xTV INV BUILT-IN FOR A CLEAN LOOK

SIM2xTV⁽¹⁾ shares the same light engine specifications, but differs in its physical design. Custom bracketry and an adjustable light engine ensure that SIM2xTV INV can be perfectly positioned to the wall/screen. Specifically designed for discreet installations, SIM2xTV INV has micrometric adjustments⁽¹⁾ to achieve optimum alignment.

SIM2xTV INV must be placed in a forced air flow rack design or furniture that uses fans or blowers to remove heat and ensure a steady flow of air through the rack enclosure.

The finishing touch is that all that is visible is the luxurious, top crystal glass surface.

⁽¹⁾ Patents pending.

Contact your SIM2 Sales representative or SIM2 office or send an email to sim2xtv@sim2.com for additional details, exact product measurements and info on installation prior to order.



DISPLAY

Technology: 1 Chip DMD 1080p
 Resolution: Full HD (1920 x 1080 pixels)
 Light source: LASER (lifetime approx. 20.000 hours)
 Adaptive contrast
 Brightness: up to 2.900 Ansi lumens (in 2D mode)
 3D active technology - DLP Link
 3D Features (1080p resolution)
 Audible Noise: <28dB (Eco Mode)

INSTALLATION

Lens throw ratio: 0,25:1
 Picture Size" 85" - 110"

INPUTS/OUTPUTS

3x HDMI
 1x Composite Video (RCA)
 1x RS-232 (D-sub 9 pins)
 1x miniUSB (B type - Service)
 1x USB (A type - host mode)
 1x 3.5mm jack/stereo audio

GENERAL SPECIFICATIONS

Projector weight: 13.5 Kg. (29.8 lbs)
 Projector dimensions (WxHxD): 537 x 115 x 383 mm
 (21.1" x 4.5" x 15.1")
 Standard Cabinet⁽¹⁾ Color: Black Crystal Glass⁽¹⁾
 surface

STANDARD ACCESSORIES

2 x Remote Control
 Power Cord
 User Manual
 SIM2 crystal glass cleaning kit and gloves
 Fine Tuning installation kit

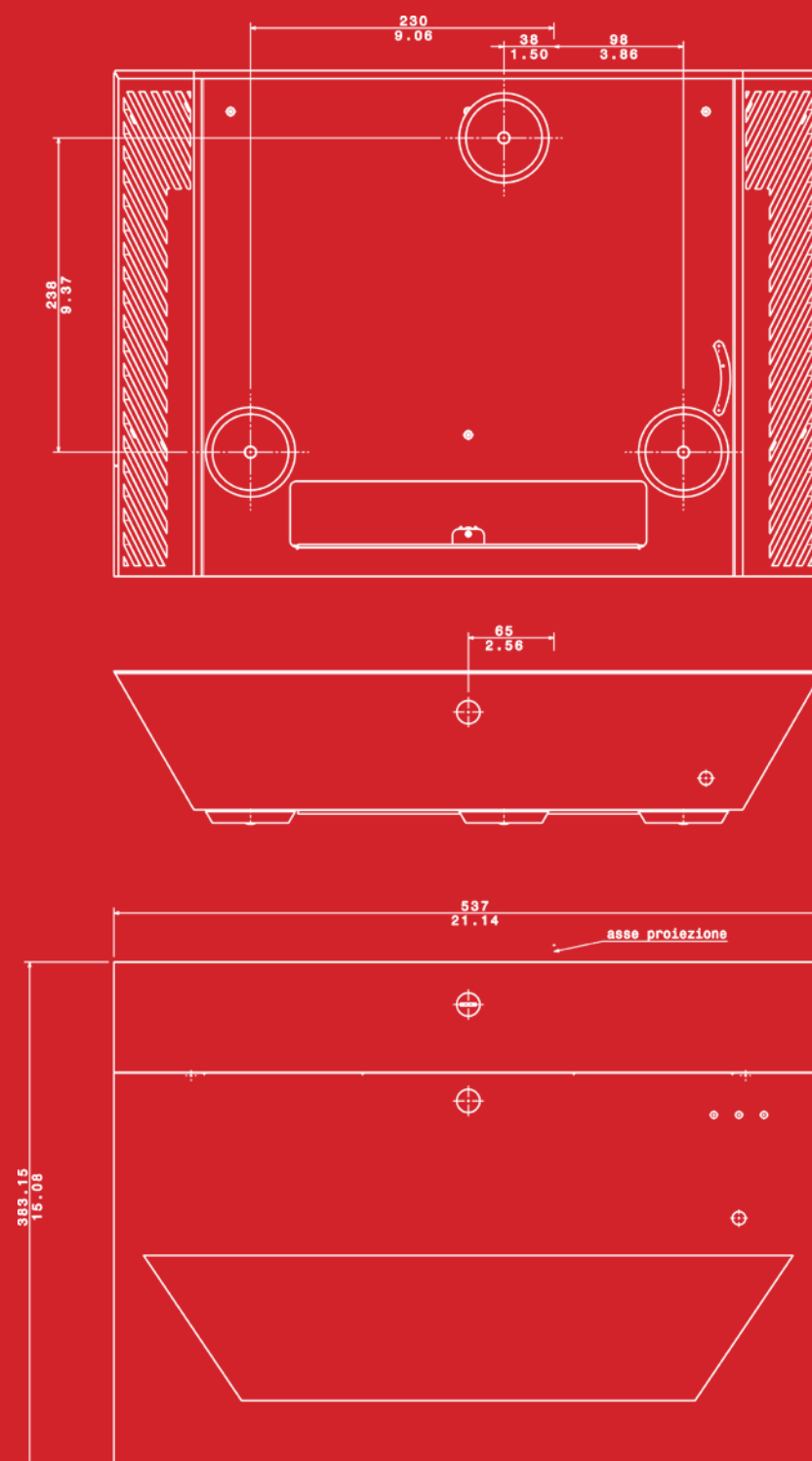

DANGER!
 LASER RADIATION.
 Do not stare into beam.
 Class 2 Laser Product.

SIM2 xTV

TECHNICAL SPECIFICATIONS

⁽¹⁾ Patents pending.

SIM2xTV INV TECHNICAL SPECIFICATIONS

⁽¹⁾ Patents pending.

⁽²⁾ Contact your SIM2 Sales representative or SIM2 office or send an email to sim2xtv@sim2.com for exact product measurements and info on installation prior to order.

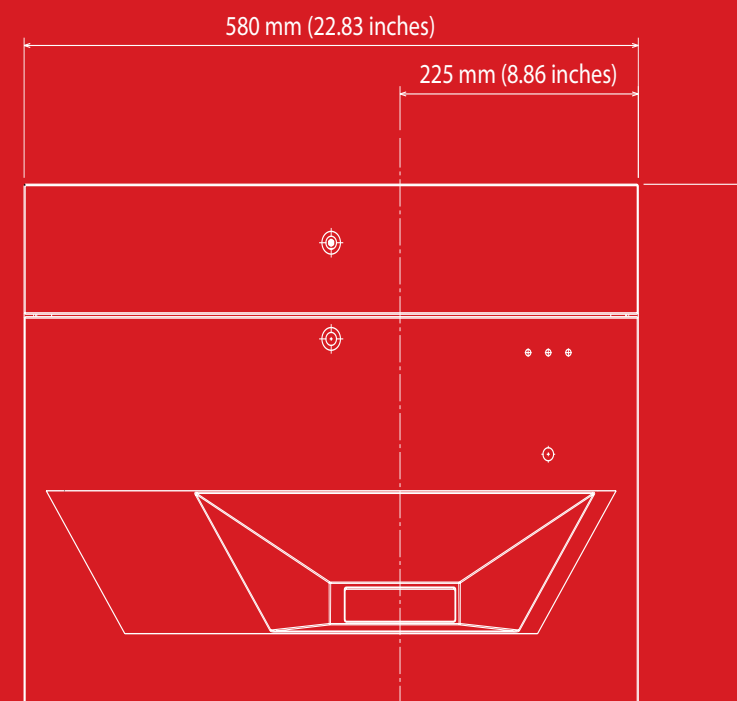
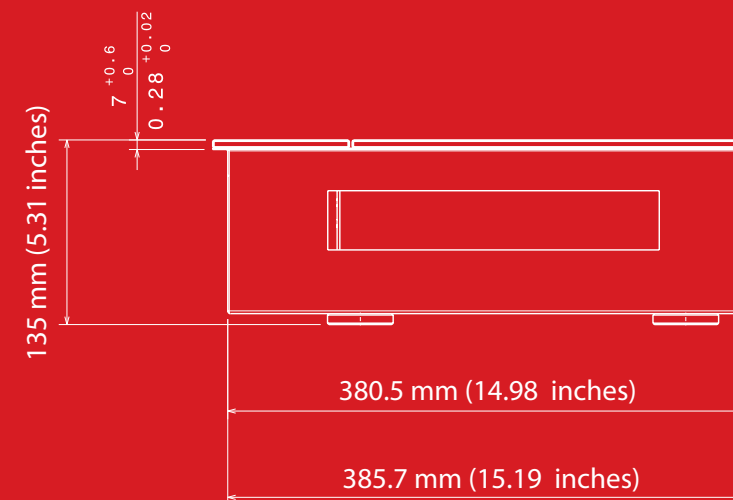
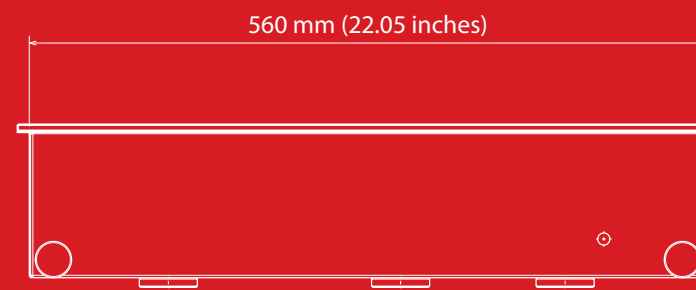

DISPLAY

Technology: 1 Chip DMD 1080p
 Resolution: Full HD (1920 x 1080 pixels)
 Light source: LASER (lifetime approx. 20,000 hours)
 Adaptive contrast
 Brightness: up to 2,900 Ansi lumens (in 2D mode)
 3D active technology - DLP Link
 3D Features (1080p resolution)
 Audible Noise: <28dB (Eco Mode)

INSTALLATION

Lens throw ratio: 0.25:1
 Picture Size⁽¹⁾ 85" - 110"

INPUTS/OUTPUTS

3x HDMI
 1x Composite Video (RCA)
 1x RS-232 (D-sub 9 pins)
 1x miniUSB (B type - Service)
 1x USB (A type - host mode)
 1x 3.5mm jack/stereo audio

GENERAL SPECIFICATIONS

Projector weight: 15.5 Kg. (34.2 lbs)
 Display Depth: 385.7 mm (15.19") fine adjustments knobs included
 Display width: 580 mm (22.83") top crystal glass
 Display width: 560 mm (22.05") cabinet under crystal glass
 Display height: 135 mm (5.31") lever feet included
 Standard Cabinet⁽¹⁾ Color: Black Crystal Glass⁽¹⁾ surface

GENERAL SPECIFICATIONS

Operating consumption: 300W typical, 350W max
 Minimum cooling: 1200 BTU/h

STANDARD ACCESSORIES

2 x Remote Control
 Power Cord
 User Manual
 SIM2 crystal glass cleaning kit and gloves
 Fine Tuning installation kit



DANGER!
 LASER RADIATION.
 Do not stare into beam.
 Class 2 Laser Product.



SIM2 BV
INTERNATIONAL s.r.l.
Viale Lino Zanussi, 11
33170 Pordenone - Italy
Tel. +39 0434 383 292
info@sim2.it
www.sim2.com

SIM2 USA Inc.
10216 NW 47th Street
Sunrise FL 33351 – U.S.A.
Ph 9544422999 –
Fax 323.375.1739
www.sim2usa.com

SIM2 BRIONVEGA Co. Ltd.
Room 302-303, No. 244
Liaoning Road
200080, Shanghai, P.R.C.
Tel/Fax: 86-21-62881991 /
+86 15921452996
InfoCHINA@sim2.com
www.sim2.com

